



UNIVERSITY COLLEGE TATI (UC TATI)

FINAL EXAMINATION QUESTION BOOKLET

COURSE CODE	: BME 2093
COURSE	: PRESS TOOL DESIGN
SEMESTER/SESSION	: 1-2023/2024
DURATION	: 3 HOURS

Instructions:

1. This booklet contains 5 questions. Answer **ALL** questions.
2. All answers should be written in answer booklet.
3. Write legibly and draw sketches wherever required.
4. If in doubt, raise your hands and ask the invigilator.

DO NOT OPEN THIS BOOKLET UNTIL YOU ARE TOLD TO DO SO

THIS BOOKLET CONTAINS 5 PRINTED PAGES INCLUDING COVER PAGE

PRESS TOOL DESIGN (BME 2093)

QUESTION 1

- a) **Classify** between piercing and blanking process. (3 marks)
- b) **Sketch** the guide plate tool and name all the plates. (3 marks)
- c) **Distinguish** between cut-off and parting-off tools in type of press tool. (3 marks)

QUESTION 2

- a) **Explain** the term "Theory of Shearing" in stamping process. (3 marks)
- b) **Identify** the critical stages of shearing for cutting the sheet of and show the graph of these critical stages. (3 marks)
- c) **Explain** stepped punch method which can be used to reduce cutting force. **Sketch** the diagram to support your answer. (3 marks)

QUESTION 3

- a) **Explain** what is the land and how to determine the land height for a particular process? (4 marks)
- b) **Explain** what the effects if the excessive and insufficient cutting clearance were used for tooling referring to burr size and cut band. (8 marks)
- c) **Explain** how to determine the die size and its thickness. **Sketch** the diagram to support your answer. (8 marks)
- d) **Illustrate how** to remove the blank in case of straight wall without angular clearance is used? **Sketch** the diagram to support your answer. (8 marks)

PRESS TOOL DESIGN (BME 2093)

QUESTION 4

- a) **Classify** the punches used in the press tool. Sketch these punches and what are the operation can be done through these punches. (8 marks)
- b) **Distinguish** between travelling and fixed stripper. Sketch the diagram to show these types of strippers. (8 marks)
- c) **Outline** FIVE (5) factors which are influenced the design of a die block. (5 marks)
- d) **Explain** the differences between solid die and split die. Sketch the diagram to support your answer. (6 marks)

QUESTION 5

Note: Refer to Figure PT1 to answer question 5b and 5c.

- a) **Explain** why the component has to be studied first before designing the strip layout for a particular tooling. (6 marks)
- b) **Sketch** the strip layout for the component and **state** clearly the process. Notes: Use direct piloting and wide run for the strip layout. (6 marks)
- c) **Calculate** the following for designing the tool as shown in Figure PT1.
- i. Economic factor (use scrap bridge 2.0 mm) (3 marks)
 - ii. Total cutting force to shear the component (9 marks)
 - iii. Machine tonnage (3 marks)

PRESS TOOL DESIGN (BME 2093)

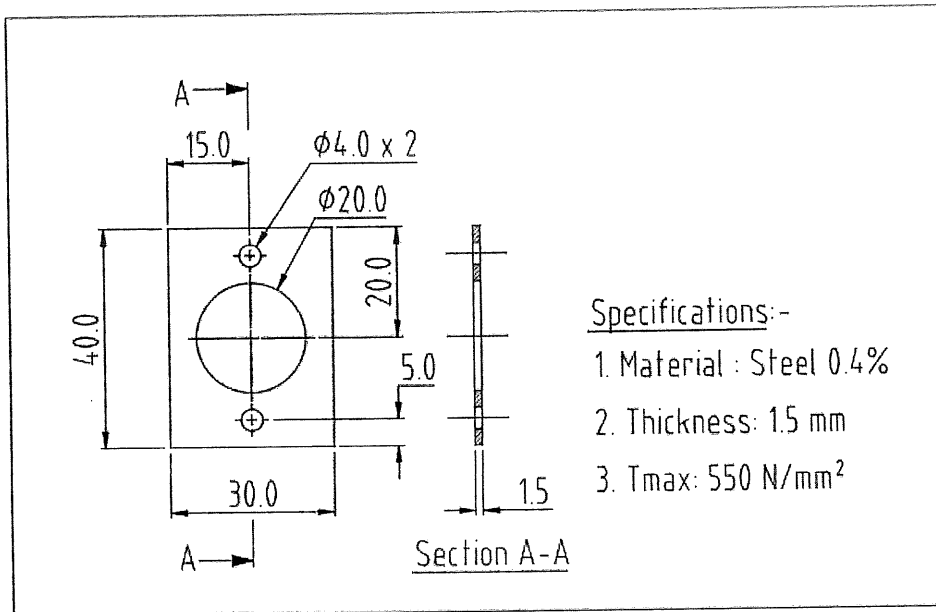

Figure PT1

-----End of question-----

RUBRIC

Criteria	Marks
All question answered will be marked according to the answer schema	/100

PRESS TOOL DESIGN (BME 2093)

APPENDIX 1**Side Scrap and Scrap bridge**

Sheet Thickness (mm)	Strip Width (mm)			
	Up to 10	10 - 50	50 - 100	100 - 150
0.5	1.5	2.0	3.0	3.5
1.0	1.0	1.75	2.0	2.5
1.5	1.5	2.0	2.5	3.0
2.0	2.0	2.5	3.0	3.5
3.0	2.0	3.5	4.0	4.5

Economic Factor

$$E.F = \frac{\text{Area of component} \times \text{No. of Row} \times 100}{\text{Width of Strip} \times \text{pitch}}$$

Cutting/Shearing Force, F

$$\text{Cutting/Shearing Force, } F = l \times s \times \tau_{\max}$$

where,

- l = length of periphery to be cut in mm
- s = stock thickness in mm
- τ_{\max} = shear strength in N/mm²

Cutting Clearance for sheet thickness up to 3 mm

$$\text{Clearance (for one side)} = C \times s \times \sqrt{\left(\frac{\tau_{\max}}{10}\right)}$$

Cutting Clearance for sheet thickness above 3 mm

$$\text{Clearance (for one side)} = (1.5 \times C \times s - 0.015) \times \sqrt{\left(\frac{\tau_{\max}}{10}\right)}$$

where,

- C = a constant = 0.01
- s = stock thickness in mm
- τ_{\max} = shear strength in N/mm²

